



# LES ANNEES 30. AVIONS CIVILS FRANÇAIS

## Le COLIBRI LEOPOLDOFF .L3.

à moteur Salmson .9ADR

Documents: L'Air pour les Jeunes

- Décollage
- Les Ailes
- Les cahiers du RSA
- le MRA

A existé en version L.6 à moteur 75cv  
Régnier 4 Cyl inversé et en version  
L.53 à moteur Continental 4 Cyl  
flat four de 65cv

Calage axe  $\approx -3^\circ$   
Capot couleur aluminium

Maquette Volante taille "PEANUT"

Longueur : 9" = 230mm

Dessiné par E. Fillon

Aéromodéliste

Centrage

Couleurs possibles : Rouge et Jaune ; blanc et bleu  
ou entièrement aluminium avec matricule en noir

Leopoldoff  
"Colibri"

texte  
en noir

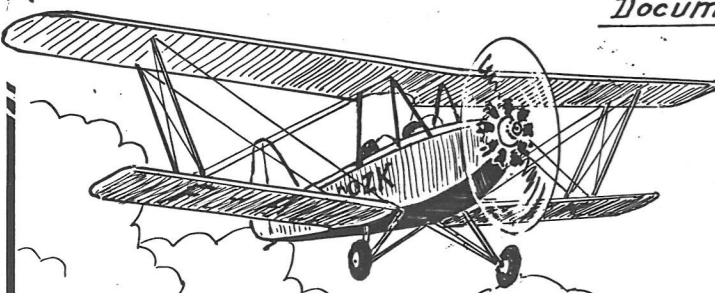

Tableaux de bord



Mâts de cabane  
bambou  $\phi 1$

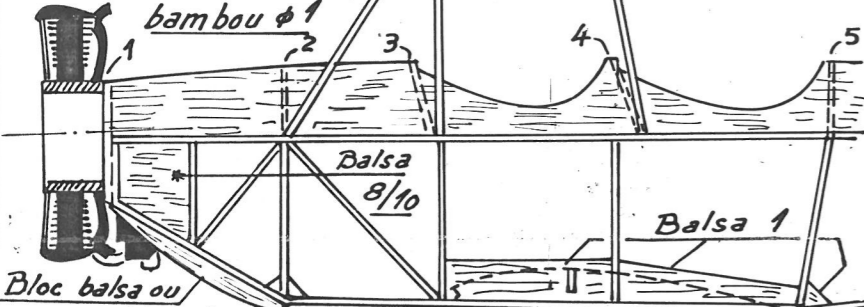

Bloc balsa ou Styrofoam

Calage  $\approx 1^\circ$  droite

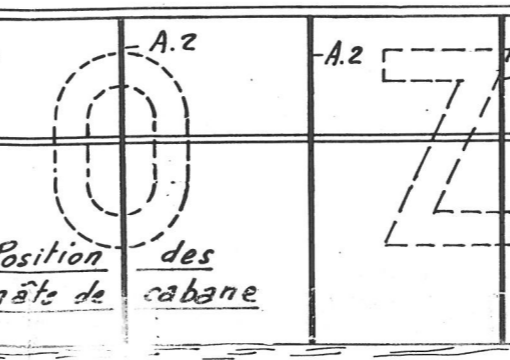
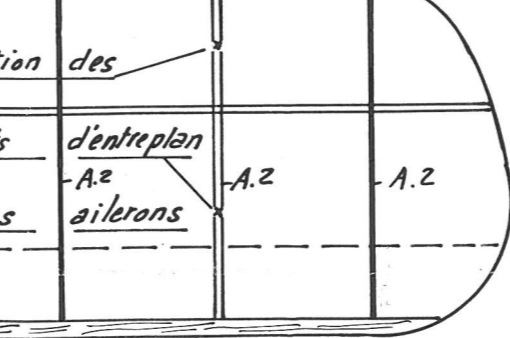
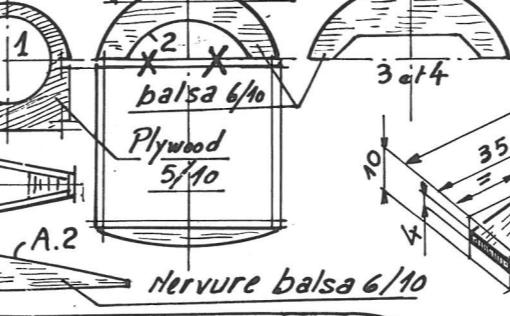
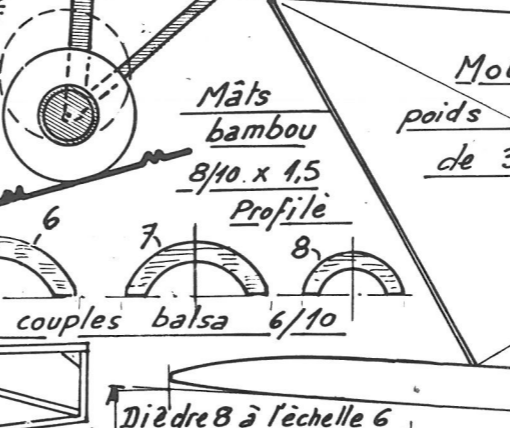
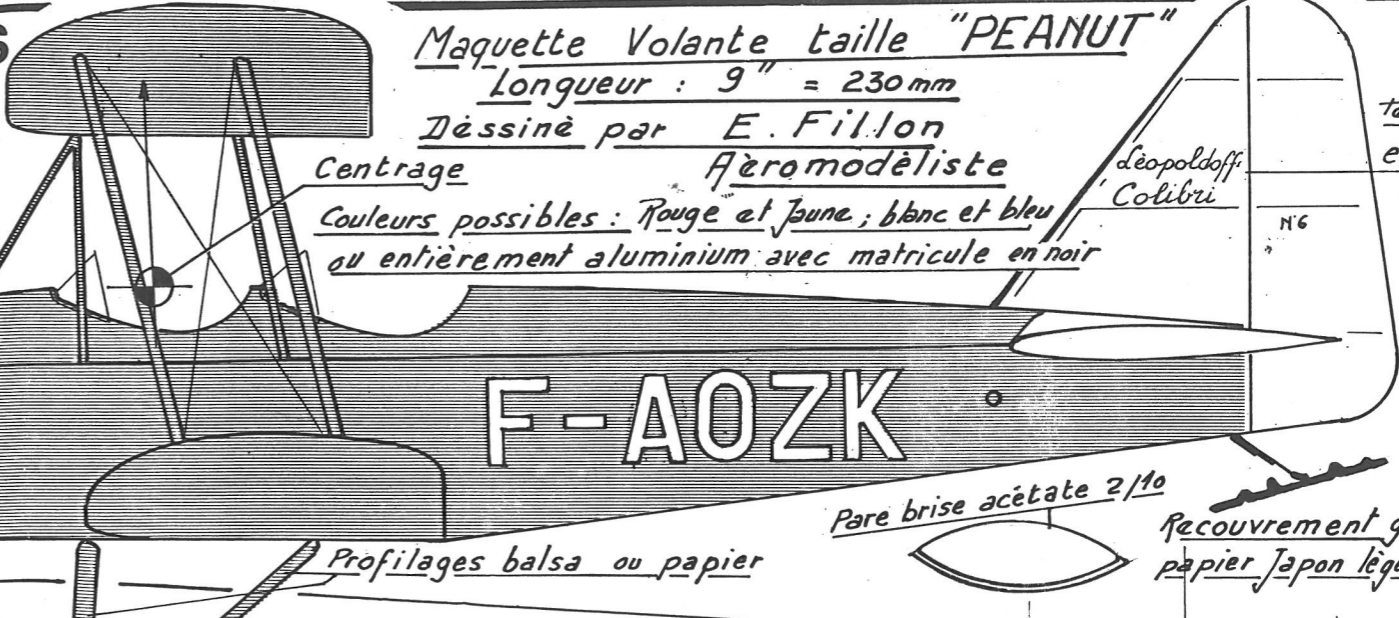
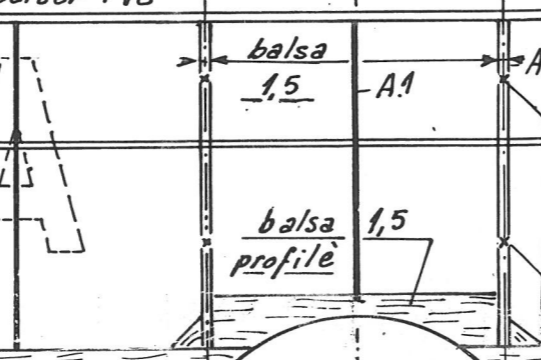
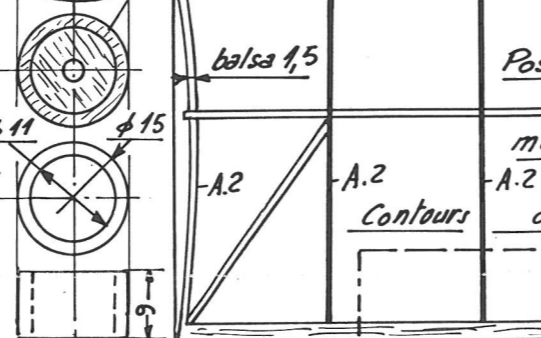
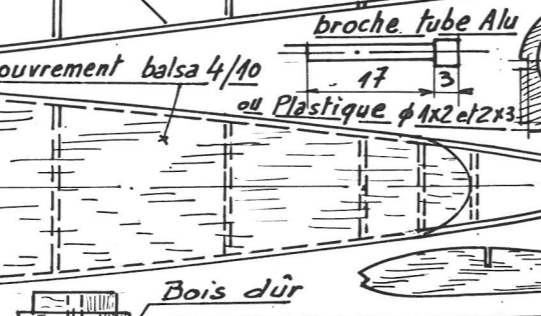
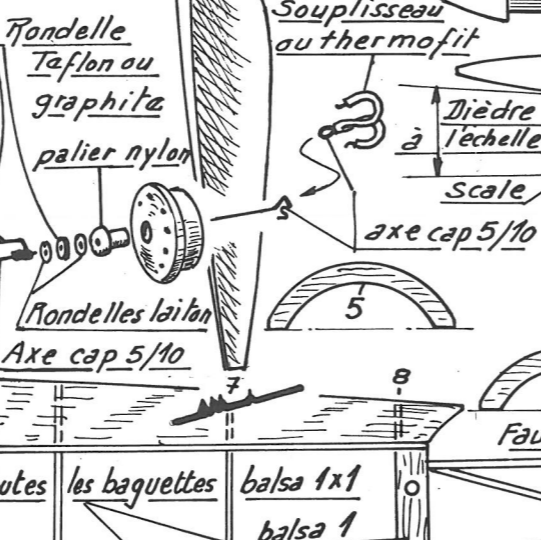
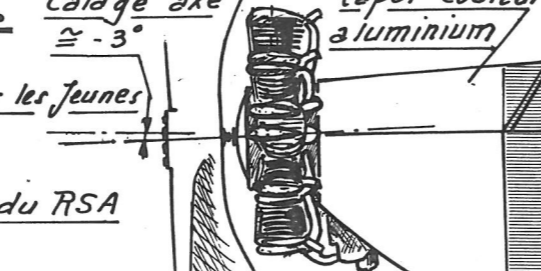
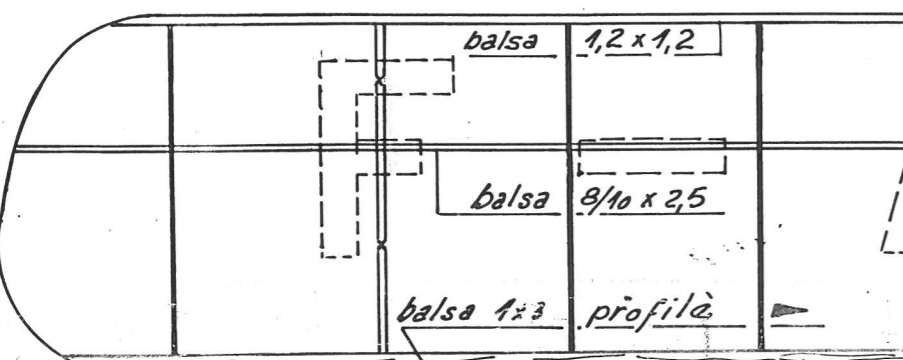
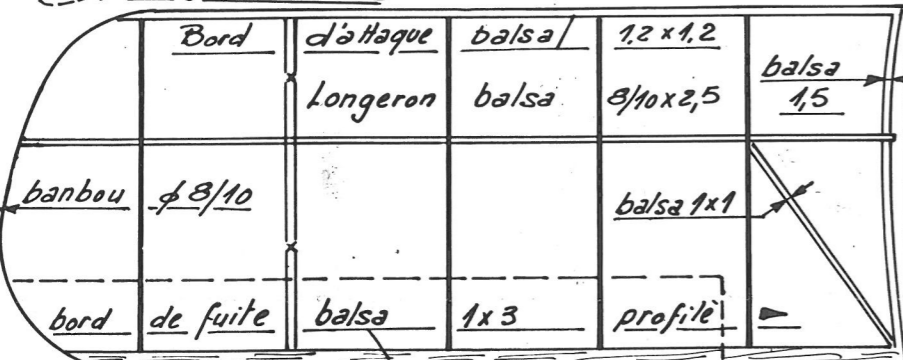

Moteur caoutchouc suivant poids du modèle : 1 boucle de 300 de long poids 2,3 à 4 gr

Hélice balsa ou Hélice plastique du commerce  $\phi 120$  à  $140$

